

LEDILSTAR-L for Lighting Ostar® LE W EXX

OSRAM

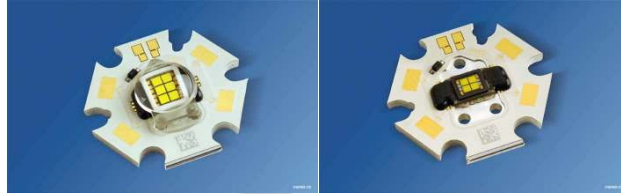

LEDILSTAR-L-S



- Use with Ostar® LE W Exx series of white LED modules
- **Patented** system for creating a homogeneous, round light pattern without traces of light from single chips (mixing of light inside the lens)
- Lensmaterial optical grade PC (polycarbonate) with high UV and temperature resistance (130°C/260°F)



LEDILSTAR-L-W

- Extremely high optical efficiency, >80%, despite of strong mixing of light and large light source
- No lens holder. Fastening to heat sink
 - o with a few glue drops or
 - o 2 screws or
 - o by clamping
- Diameter 35 mm (MR11 size)
- Easy build of a complete luminaire using LEDILSTAR, Ostar® and heat sink
- Mechanical CAD models available upon request
- Both lens types have the same outer dimensions, which allow a cross use of them in the same lighting fixture.

LENS TYPES

NAME	ORDERING CODE	FWHM Angle, LE W E2A	FWHM Angle, LE W E2B	FWHM Angle, LE W E3A	FWHM Angle, LE W E3B
LEDILSTAR lighting SPOT	LEDILSTAR-L-S (n. 10265)	±6°	±8°	±6°	±8°
LEDILSTAR lighting WIDE	LEDILSTAR-L-W (n. 10266)	±16°	±18°	±16°	±18°

MEASUREMENT DATA & PHOTOGRAPHS

LEDILSTAR-L-S

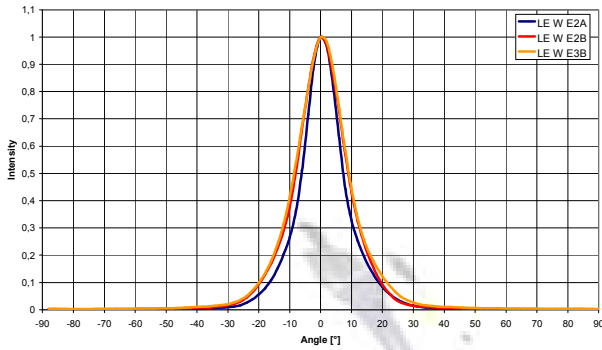

LEDILSTAR-L-W

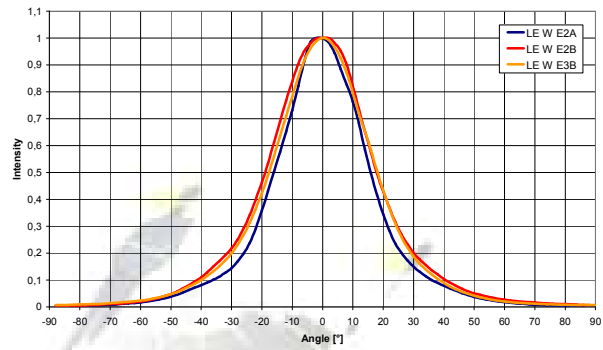

All measurements done at Osram Opto Semiconductors GmbH in Regensburg, Germany.

DIMENSIONS & ASSEMBLY

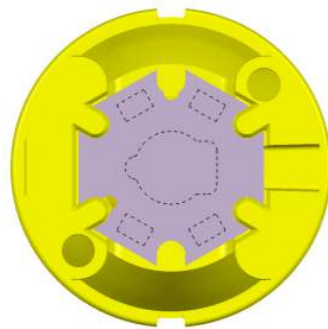
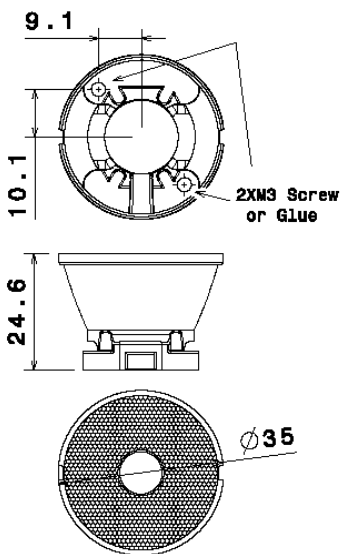

Position of Ostar

Screwing of lens

© Ledil Oy - PRELIMINARY - Subject to change without prior notice